

Mazak

FJV-35 SERIES

SMOOTH
TECHNOLOGY

FJV-35 SERIES

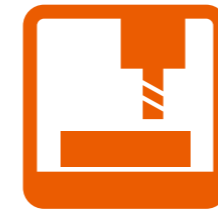

35/60
35/80
35/120

YAMAZAKI MAZAK CORPORATION

1-131 Takeda, Oguchi-cho, Niwa-gun, Aichi-pref., Japan
TEL : +(81)587-95-1131 FAX : +(81)587-95-2717

www.mazak.com

- Specifications are subject to change without notice.
- This product is subject to all applicable export control laws and regulations.
- The accuracy data and other data presented in this catalogue were obtained under specific conditions. They may not be duplicated under different conditions. (room temperature, workpiece materials, tool material, cutting conditions, etc.)

FJV-35 SmoothG series 16.05.1000 E 99J278316E0 

Mazak

Advanced features of the Mazak SmoothG CNC

Touch screen operation—Operate similar to your smart phone / tablet

PC with Windows® 8 embedded OS

Fastest CNC in the world—Latest hardware and software for unprecedented speed and precision

Easy conversational programming of multiple surface machining

Smooth user graphical interface and support functions for unsurpassed ease of operation

Fine tuning functions—Easily configure machine parameters for different workpiece materials and application requirements

MTConnect® ready—Convenient networking

Windows is a registered trademark of Microsoft Corporation in the United States and other countries. MTConnect is a registered trademark of AMT in the United States and other countries.

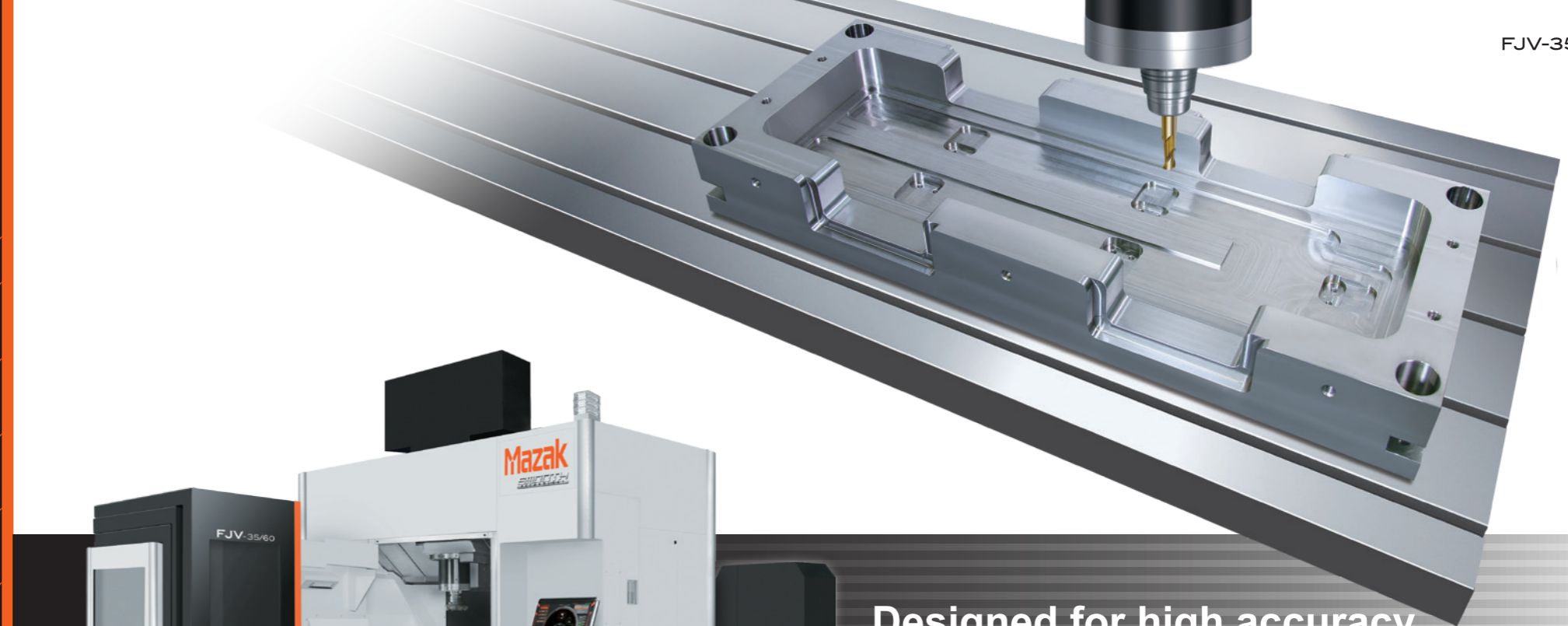

Designed for high accuracy, high efficiency machining of long, flat workpieces

High precision, high productivity, double-column machining center

FJV-35 SERIES

FJV-35/60
Shown with optional end cover window, status worklight, additional work light, remote manual pulse generator and chip conveyor

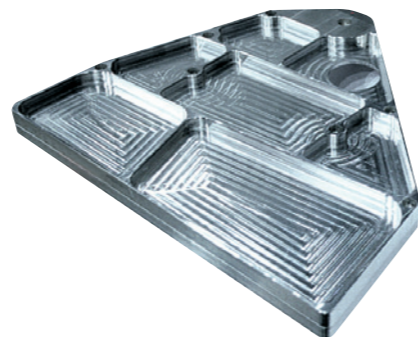
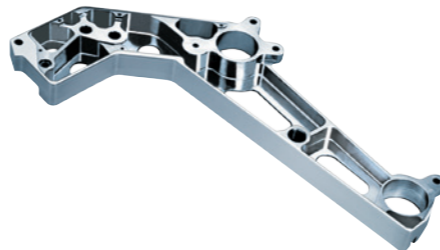

Large variety of machine sizes available to meet the requirements of a wide range of workpiece sizes

Large variety of available spindle specifications to meet the production requirements of virtually any workpiece material

Non-cutting time is reduced thanks to the utilization of linear roller guides on all axes and direct servo driven ball screws

Multi-surface attachment for higher productivity **OPTION**

FJV-35/60	: X-axis stroke 1500 mm
FJV-35/80	: X-axis stroke 2000 mm
FJV-35/120	: X-axis stroke 3000 mm
10000 rpm	: No.50, BBT-50, HSK A100
7000 rpm	: No.50, BBT-50, HSK A100
18000 rpm	: No.40, BBT-40, HSK A63



Standard type angle holder shown

MAZATROL
SMOOTHG
SMOOTHG

Higher Productivity

3 spindle specifications are available to meet a wide variety of workpiece material requirements

Standard 10000 rpm spindle

No. 50 taper 10000 rpm, 37 kW (50HP) standard spindle for a variety of machining applications from high speed machining of aluminum to heavy duty machining of steel workpieces.

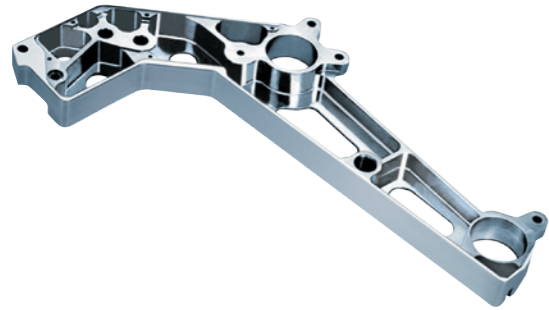

High torque 7000 rpm spindle OPTION

7000 rpm spindle with output of 30 kW (40 HP) is optionally available for high torque and heavy duty machining of steel materials.

Max. torque : 774 N·m, spindle taper : No.50

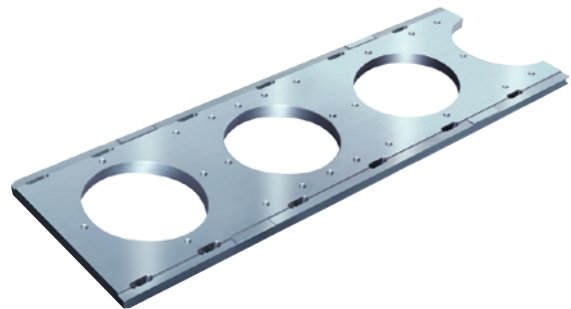

High speed 18000 rpm spindle OPTION

18000 rpm spindle with output of 35 kW (47 HP) and maximum torque of 168 N·m is optionally available for high speed machining of aluminum and other nonferrous materials.

Spindle taper : No.40.



Spindle speed	10000 rpm	7000 rpm OPTION	18000 rpm OPTION
Spindle output	1 min. rating	44.4 kW (60 HP)	—
	30 min. rating [40% ED]	37 kW (50 HP)	35 kW (47 HP)[50 % ED]
	Cont. rating	30 kW (40 HP)	26 kW (35 HP)
Tool shank	No.50, BBT-50, HSK A100	No.50, BBT-50, HSK A100	No.40, BBT-40, HSK A63

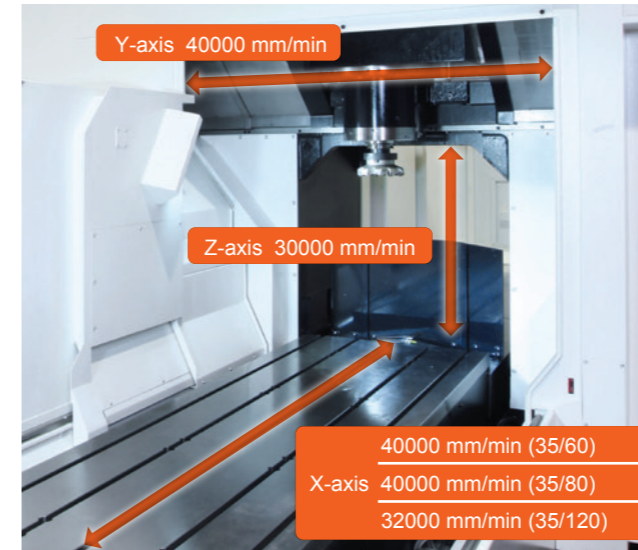

Faster rapid traverse rate

By utilizing linear roller guide on all axes and direct servo driven ball screws, not only is non-cutting time reduced — high accuracy machining is ensured even at high speed feedrates. Additionally, the ball screw core cooling system ensures stable machining accuracy over extended periods of high speed operation.

		FJV-35
X-axis	35/60	40000
	35/80	40000
	35/120	32000
Y-axis		40000
Z-axis		30000

(mm/min)

Compact spindle cartridge

The spindle is designed to provide an increased machining area and features a compact spindle cartridge for excellent workpiece accessibility with minimum interference. Additionally, the compact spindle cartridge allows workpieces to be efficiently machined at the optimum cutting conditions.



Designed for high efficiency machining of thin workpieces

The short 160 mm (previous model : 200 mm) distance from spindle nose to table surface of the FJV-35 allows thin workpieces to be efficiently machined with the optimum cutting conditions for No. 50 taper tools.

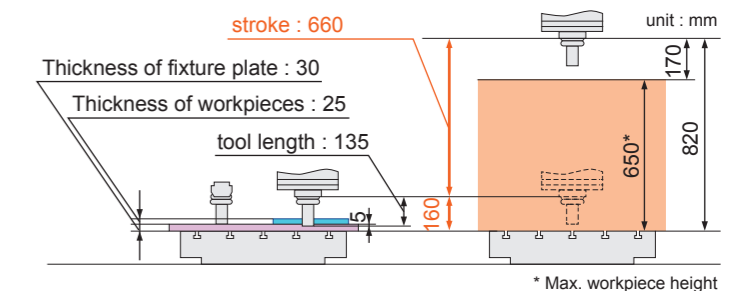

Higher Productivity

Multi-surface machining attachment for higher productivity

Multi-surface attachment

(Option for 10000 rpm and 7000 rpm No.50 spindle)

Side-surface machining can be performed by just changing the spindle index angle of the special clamping unit and angle tool mounted on the machine spindle. The ability to machine multiple surfaces of large workpieces in a single setup realizes unsurpassed productivity

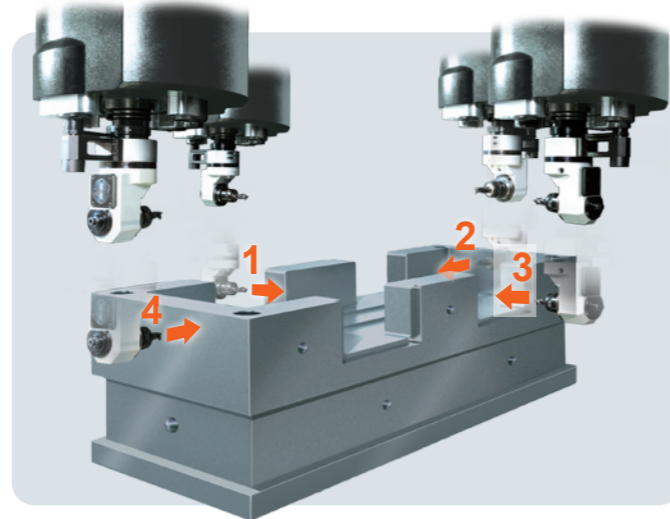

Available angle tool holders

	Standard	High speed	Heavy duty
Type of angle holder			
Tools	Facemill: Max. ø80 mm Endmill: ø1.5 mm ~ 20 mm Drill: ø1.5 mm ~ 20 mm Tap: M3 ~ 12	— ø5.8 mm ~ 20 mm ø5.8 mm ~ 20 mm —	Max. ø100 mm 330 mm (Distance from main spindle center to end of tool) 330 mm (Distance from main spindle center to end of tool) 330 mm (Distance from main spindle center to end of tool)
Tool magazine	No.50, 30-, 60-tool magazine	No.50, 30-, 60-tool magazine	Special tool magazine for heavy-duty type (Max. 3 tools)

5 surface machining center FJV 5 Face-35 series

MAZAK 5 Face angle tool holder (Heavy duty B-type angle holder + ATC) and tool magazine (max. 8 tools) are standard equipment.

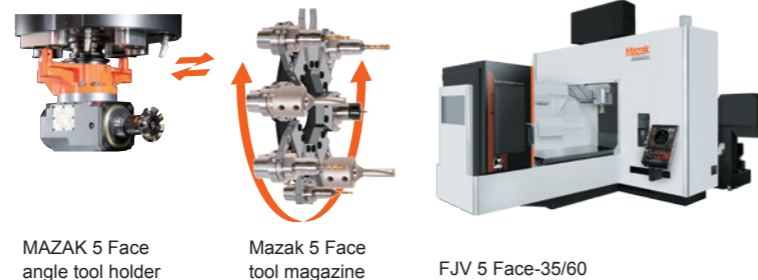

Convenient programming even for multi-surface machining

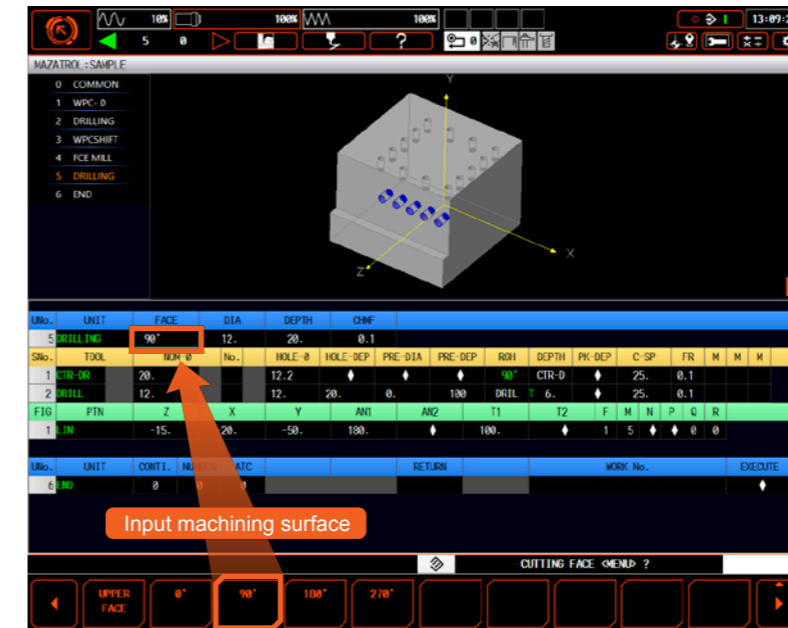

Operation is available for both MAZATROL and EIA programs. Side-surface machining is easily programmed using the conversational MAZATROL format. All that is required is to enter which surface is to be machined followed by the normal data entry.

Coordinate system and machining surface

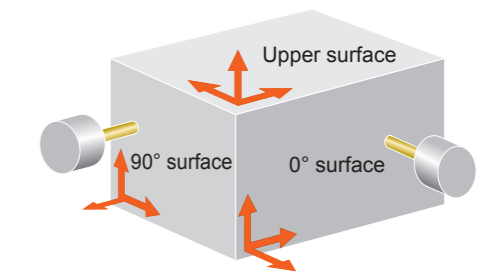

Easy registration of angle attachment

Distance from the angle tool center line to spindle gauge line and from spindle center line to end of tool are automatically registered the same as a standard tool by the optional laser tool measuring system.

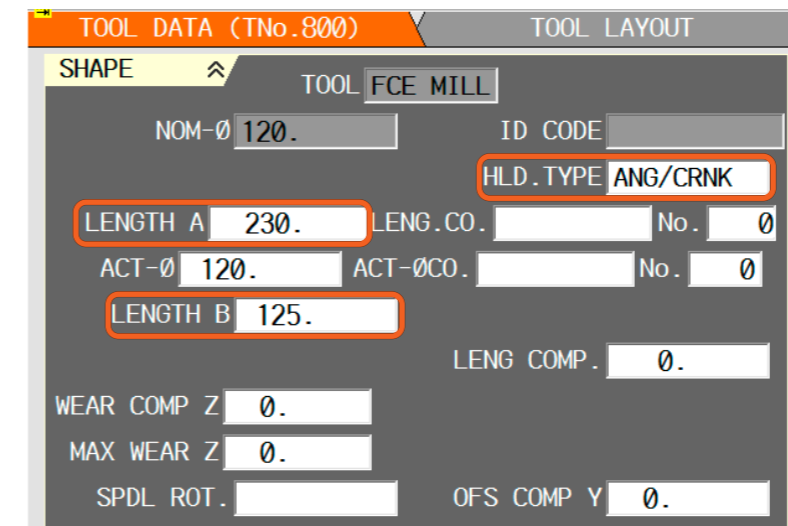

Laser tool measuring system OPTION

Laser tool measuring system automatically measures the tool length and diameter of milling tools and inspects for breakage.

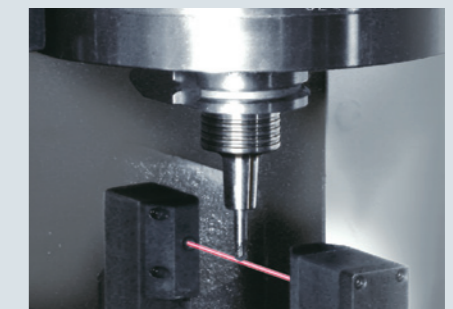

Intelligent Machine



Yamazaki Mazak has developed a variety of functions for the improvement of productivity, high accuracy machining and operator support. A variety of unique technologies has been developed that incorporates the expertise of experienced machine operators that realizes unsurpassed productivity and higher accuracy machining.

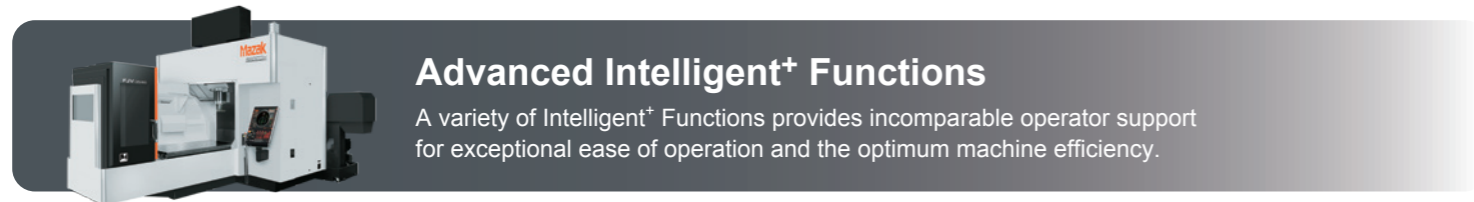

Advanced Intelligent+ Functions

A variety of Intelligent+ Functions provides incomparable operator support for exceptional ease of operation and the optimum machine efficiency.

Set up

ISS+ Machine Interference Prevention
INTELLIGENT SAFETY SHIELD

When an operator manually moves the machine axes for setup, tool measurement or changing inserts, the CNC shows a synchronized 3D model on the display for checking machine interference. If any machine interference occurs, the machine motion automatically stops.

MVA+ Verbal Message System
MAZAK VOICE ADVISER

Verbal support for machine setup and safe conditions confirmation.

Machining

SMC+ Convenient Parameter Setting and Fine Tuning Function
SMOOTH MACHINING CONFIGURATION

Machining time, finished surface smoothness and machining shape can be adjusted for improved productivity.

VAC Variable Acceleration Control Function
VARIABLE ACCELERATION CONTROL
Variable acceleration control is a new function which permits the faster acceleration capability of linear axes to be used whenever possible. The slower acceleration of the rotary axes is not used for all program commands, resulting in faster machining cycle times.

AVC Minimized Vibrations
ACTIVE VIBRATION CONTROL
Machine vibration can be reduced to perform excellent machining accuracy and high-speed machining.

Without ACTIVE VIBRATION CONTROL
Cutting feedrate : 3000 mm/min

With ACTIVE VIBRATION CONTROL
Cutting feedrate : 3000 mm/min



Maintenance

IPS+ Comprehensive Spindle Monitoring
INTELLIGENT PERFORMANCE SPINDLE

The INTELLIGENT PERFORMANCE SPINDLE monitors a variety of properties such as temperature with sensors housed in the spindle and provides useful information to the operator. Thanks to this monitoring, production loss due to machine down time can be minimized.



▲ Condition check
Temperature as well as the motor load can be displayed.

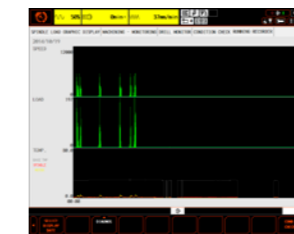

▲ Running recorder
Operation status of milling spindle (rpm / motor load) can be recorded for up to one year.

IMS+ Comprehensive Maintenance Monitor
INTELLIGENT MAINTENANCE SUPPORT

Useful information for improved preventative maintenance to prevent unexpected machine downtime.



SCC Seamless Corner Control
SMOOTH CORNER CONTROL
Improved finished surfaces and reduced cycle times by optimized acceleration / deceleration when machining corners.

Other systems
Move to next command position after reaching current command position

SMOOTH CORNER CONTROL
Move to next command position within tolerance band

ITS+ Heat Displacement Control
INTELLIGENT THERMAL SHIELD

The INTELLIGENT THERMAL SHIELD is an automatic compensation for room temperature changes, which realizes enhanced continuous machining accuracy. MAZAK has performed extensive testing in a variety of environments in a temperature controlled room and has used the results to develop a control system that automatically compensates for temperature changes in the machining area. Changes in the room temperature and compensation data are shown visually.



Temperature and compensation are displayed on MAZATROL SmoothG screen. Operator can adjust compensation by looking at the data.

Standard Machine Specifications

		FJV-35/60	FJV-35/80	FJV-35/120
Stroke	X-axis (table left / right)	1500 mm	2000 mm	3000 mm
	Y-axis (spindle head back / forth)	800 mm		
	Z-axis (spindle head up / down)	660 mm		
Table	Distance from table top to spindle nose	160 mm ~ 820 mm		
	Effective width between columns	860 mm		
	Table size	1740 mm × 750 mm	2240 mm × 750 mm	3240 mm × 750 mm
	Table load capacity (evenly distributed)	2500 kg	3000 kg	
	Table top surface	18 mm T-slot × 5 150 mm pitch		
Spindle	Spindle speed	35 rpm ~ 10000 rpm		
	Gear ranges	1-Stepless		
	Spindle taper	No.50		
	Spindle bearing ID	ø100 mm		
	Spindle acceleration time to top speed	3.0 s (0 rpm → 10000 rpm)		
Feedrate	Rapid traverse rate (X-axis)	40000 mm/min	32000 mm/min	
	Rapid traverse rate (Y-, Z-axes)	40000 mm/min / 30000 mm/min		
	Cutting feedrate (X-, Y-, Z-axes)	1 mm/min ~ 30000 mm/min	1 mm/min ~ 20000 mm/min	
Automatic tool changer	Tool shank	No. 50		
	Tool magazine capacity	30		
	Max. tool diameter / length (from gauge line) / weight	ø125 mm / 380 mm / 20 kg		
	Max. tool diameter with adjacent pockets empty	ø210 mm		
	Tool selection method	Random selection / shortest path		
	Tool change time (chip-to-chip)	5.0 s		
Motors	Spindle motor (30 min. rating [40 % ED] / cont. rating)	AC 37 kW (50 HP) / 30 kW (40 HP)		
	Flood coolant pump motor (50 Hz / 60 Hz)	730 W / 1210 W		
Power requirement	Required power capacity (30 min. / cont. rating)	74 kVA / 64.25 kVA	74.7 kVA / 64.95 kVA	
	Air source	0.49 MPa ~ 0.9 MPa (5 kgf/cm ² ~ 9 kgf/cm ²) / 1200 NL/min		
Machine size	Machine height	3500 mm		
	Floor space requirement	3595 mm × 5637 mm	3595 mm × 6863 mm	3595 mm × 9315 mm
	Machine weight	17600 kg	19100 kg	23100 kg
Sound	Equivalent continuous sound pressure level at operator position (depend on equipment options)	Less than 80 db (A)		

Standard and Optional Equipment

		FJV-35/60	FJV-35/80	FJV-35/120
Spindle	10000 rpm (No.50)	●	●	●
	10000 rpm (BBT-50, HSK-A100)	○	○	○
	7000 rpm (No.50, BBT-50, HSK-A100)	○	○	○
	18000 rpm (No.40, BBT-40, HSK-A63)	○	○	○
Table	Y-axis reference slot	○	○	○
	Auxiliary table	○	○	○
Tool magazine	30-tool chain-type magazine	●	●	●
	60-tool chain-type magazine	○	○	○
High accuracy	Ball screw core cooling (X-, Y-, Z-axes)	●	●	●
	Chiller unit	●	●	●
	Scale feedback (X-, Y-axes)	○	○	○
	Scale feedback (X-, Y-, Z-axes)	○	○	○
	Coolant temperature control	○	○	○
Setup	Automatic tool length measurement & tool breakage detection	●	●	●
	Laser tool measurement (up to ø210 mm)	○	○	○
	Mazak monitoring system B (optical) OMP60	○	○	○

Standard and Optional Equipment

		FJV-35/60	FJV-35/80	FJV-35/120
● : Standard ○ : Option — : N/A				
Setup	Preparation for Mazak monitoring system B	○	○	○
	Absolute position detection	●	●	●
	End cover window	○	○	○
	Remote manual pulse generator (wired)	○	○	○
	Remote manual pulse generator (wireless)	○	○	○
	Float-type coolant level gauge	●	●	●
Factory automation	Preparation for hydraulic fixtures 2 ports × 2 M code (one side)	○	○	○
	Preparation for hydraulic fixtures 2 ports × 4 M code (both sides)	○	○	○
	Preparation for pneumatic fixtures 2 ports × 2 M code (one side)	○	○	○
	Preparation for pneumatic fixtures 2 ports × 4 M code (both sides)	○	○	○
	Fixture seating confirmation 1 port × M code	○	○	○
	One additional axis (including servo motor amplifier)	○	○	○
	2 pallet changer (with safety cover)	○	○	—
	2 pallet changer preparation for pneumatic fixtures 2 ports × 2 M code (one side)	○	○	—
	2 pallet changer preparation for pneumatic fixtures 2 ports × 4 M code (both sides)	○	○	—
	2 pallet changer preparation for hydraulic fixtures 2 ports × 2 M code (one side)	○	○	—
	2 pallet changer preparation for hydraulic fixtures 2 ports × 4 M code (both sides)	○	○	—
	One additional axis for 2 pallet changer (including servo motor amplifier)	○	○	—
	Print out function for workpiece measuring (without printer)	○	○	○
	Angle tool for side face machining	○	○	○
Automatic power ON / OFF + warm-up operation	●	●	●	
Coolant / Chip disposal	Coolant system	●	●	●
	Large capacity coolant tank (900 L)	○	○	○
Chip disposal	Niagara coolant (requires large capacity coolant tank)	○	○	○
	High pressure coolant through spindle (7.0 MPa)	○	○	○
	Coolant through spindle 0.5 MPa with cyclone filter	○	○	○
	Coolant through spindle 1.5 MPa with cyclone filter	○	○	○
	Coolant for angle tool	○	○	○
	Cover coolant (requires large capacity coolant tank)	○	○	○
	Workpiece air blast	●	●	●
	Hand held coolant nozzle	○	○	○
	Oil skimmer (RB-200)	○	○	○
	Disk skimmer	○	○	○
	Secondary coolant filter	○	○	○
	Fully enclosed cover	○	○	○
	Mist collector (G1000)	○	—	—
	Mist collector (G2000)	—	○	—
	Mist collector (G3000)	—	—	○
	Internal spiral conveyor (inverter system)	●	●	●
	Internal chip conveyor (hinge)	○	○	○
Inverter system for internal hinge type chip conveyor	○	○	○	
Preparation for chip conveyor (rear discharge)	●	●	●	
Chip conveyor (rear discharge, CONSEP)	○	○	○	
Chip conveyor (rear discharge, hinge, abrasion resistant)	○	○	○	
Inverter system for chip conveyor	○	○	○	
Chip pan	○	○	○	
Safety equipment	Operator door interlock	●	●	●
	ATC automatic recover function	●	●	●
	Automatic fire extinguisher	○	○	○
	Pressure switch for coolant through spindle	○	○	○